

# HARVIA TOP CLASS

HKSE800400

*Harvia Topclass Combi is a unique combination of an electric heater and a steamer that provides sauna enjoyment for all senses. This heater is created for bathers who appreciate soft and humid steam and a fragrant atmosphere. The heater has luxurious soapstone cups to hold sauna fragrances and a stainless steel grate for bagged aromatic fragrances.*



## Features

Main material : Steel

H x W x D : 640.0 x 400.0 x 360.0 mm

Net weight (kg) : 16.7

Installation location : Wall

ID	GTIN	Output (kW)	Sauna room size min - max m3
HKSE800400	6417659005555	8 kW	7.0-12.0

## Related products

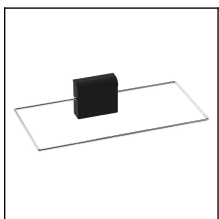

SFE-220400

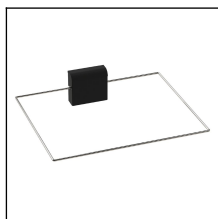

SFE-350400

## Spare parts

Product	ID	Pcs
Heating element 2670W/230V	ZSK-710	1
Heating element 2000W/230V	ZH-104	1
Soapstone cup 0 46/36	ZH-205	2
Overheating limiter switch 55.13529.100	ZSK-764	1
Thermostat 13322.090 110 Steam	ZSN-250	1
Solenoid valve	ZSS-610	1
Watertank complete KVC, manual	ZSVH-6	1
Tap R 1/4	ZH-130	1
Contactora K2 Forte	ZSF-730	1
Emptying tube with tab for KGS,TC, EB	ZH-110	1
Silicon hose pipe 12/16	ZH-175	1
Connection pipe 7/10, silicon	ZH-170	1

## Technical details

Technical data	Type / attribute	HKSE800400
Technical data	Color	Stainless Steel
	Power output	8 kW
	Stone amount (kg)	20
	Product width	400
Dimensions	Product height	640
	Product depth (mm)	360
	Net weight (kg)	16.7
	Gross weight	18
	Package width	375
	Package height	690
	Package depth	415
Safety and installation dimensions	Safety distance front (non-combustible materials)	90
	Safety distance side (non-combustible materials)	100
	Safety distance behind (non-combustible materials)	100
	Safety distance (Ceiling)	1100
	Room min. height(depends on connections and therefore from output, star/delta)	1900

Technical images

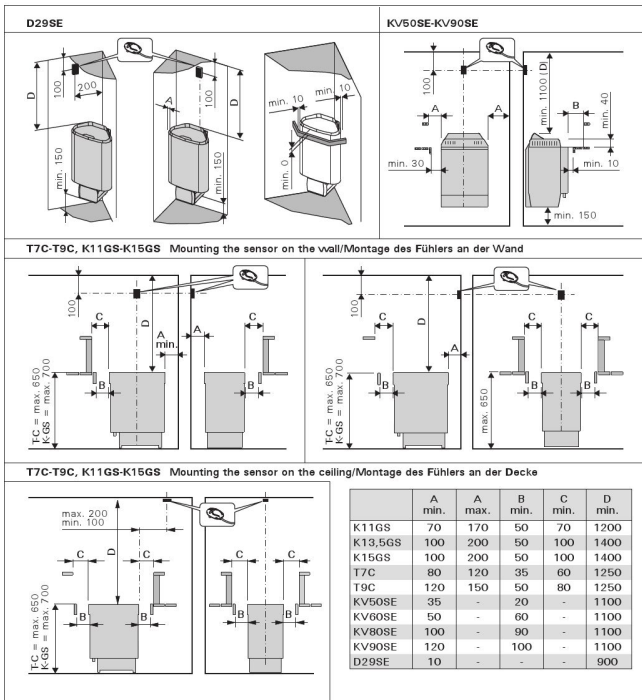

Safety distances (all dimensions in millimeters)